

ARREGLO FOTOVOLTAICO DE 4800W

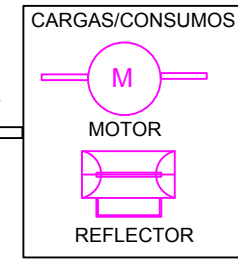

SIMBOLO	DESCRIPCIÓN
	CONECTOR MC4 SENCILLO
	PROTECCIONES TERMOMAGNETICAS DE 20 AMP
	FUSIBLE DE 20 AMP
	INVERSOR / CARGADOR EPI3000192 3000W-120Vca
	MODULO FV TRINA SOLAR 320 W. POLICRISTALINO 72 CELDAS.
	CABLE SLY296RED CAL. 8 AWG, 600V, COLOR ROJO CONEXIÓN POSITIVO
	CABLE SLY296BLK CAL. 8 AWG, 600V, COLOR NEGRO CONEXIÓN NEGATIVO
	CABLE SLY296GRN, CAL. 8 AWG, 600V, COLOR VERDE CONEXIÓN A TIERRA.
	CABLE SLY296WHT, CAL. 8 AWG, 600V, COLOR BLANCO CONEXIÓN A 120Vca.
	SISTEMA DE TIERRA FISICA KITMASTER45AB.
	BATERIA AGM 12 Vcd-110 Ah VRLA EPCOM
	CARGA / CONSUMOS, MOTORES, REFLECTORES, ETC. SIN PASAR LOS 2000W.
	RED ELECTRICA NACIONAL
	FLUJO DE CONSUMO.
	FLUJO DE CARGA.

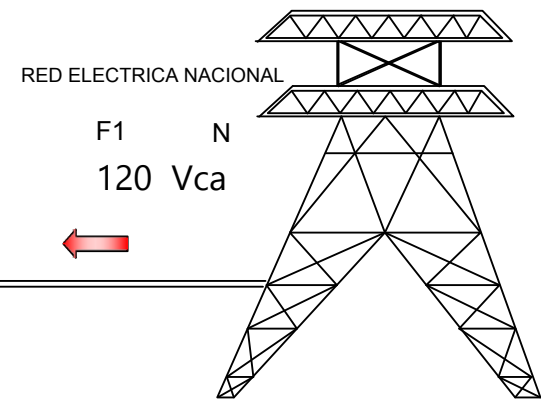
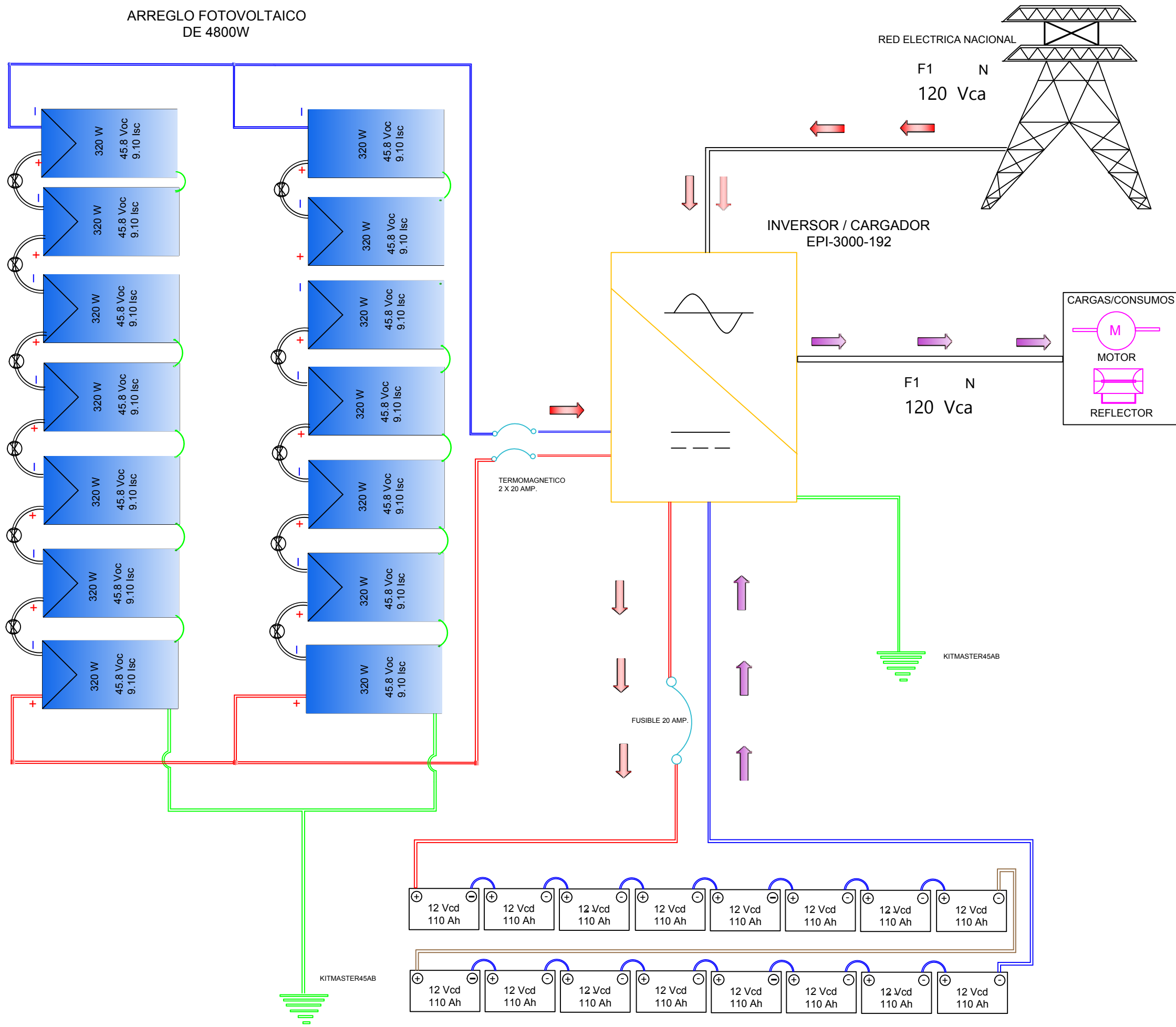